

# inurma

ENVIRONMENTAL TECHNICAL SOLUTIONS

## FICHA TÉCNICA

BANCO SILLÓN



### BANCO SILLÓN

Banco con patas de fundición dúctil pintado en martelé y 6 listones de madera tropical de 35x110x700 mm, acabada en barniz de poro abierto y tornillería de acero inoxidable.

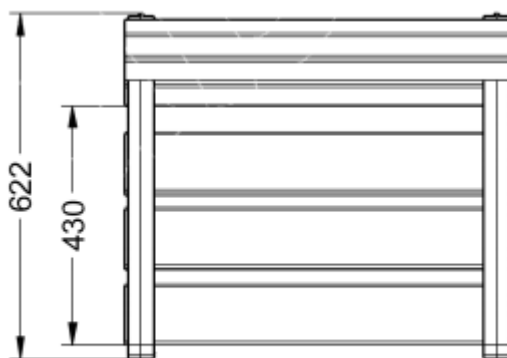
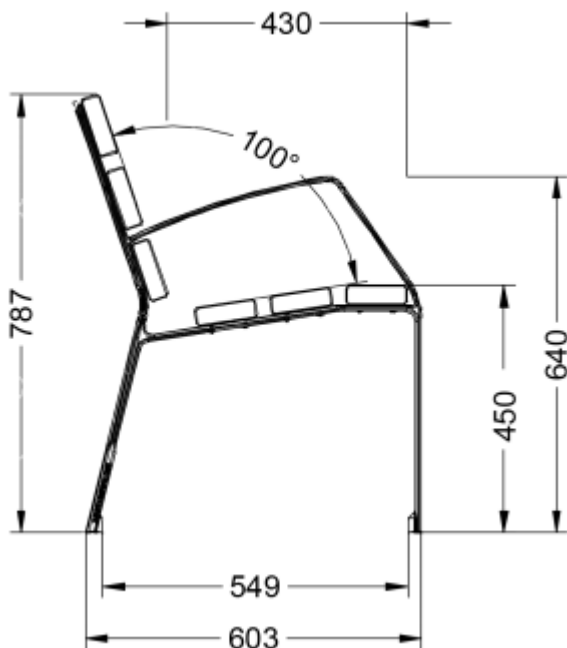
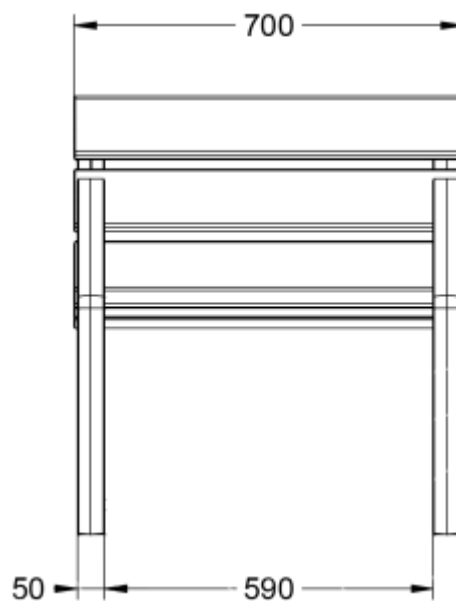

#### CARACTERÍSTICAS TÉCNICAS

1. Medidas	200 x 41 x 45 cm
2. Material	Plástico 100% reciclado